

**MACHINIST®**

**X99 U9**  
**User Manual**

# Contents

Specifications .....	1
Overview of Components .....	2
Install CPU & Fan .....	3
Install Memory .....	4
Install Expansion Card .....	5
Back Panel Connectors .....	5
USB 2.0 Port .....	5
USB 3.0 Port .....	6
RJ45 LAN Port .....	6
Audio Port .....	6
PS/2 Port .....	6
Internal Connectors .....	7
F_PANEL1 Connector .....	7
SPKR Connector .....	7
F_AUDIO1 Connector .....	7
SSD1~3: NVME M.2 Slot .....	8
WIFI1: WIFI M.2 Slot .....	8
JCMOS: Clear CMOS .....	9
JCOM1: Serial Port Connector .....	9
JWR2: Control Front USB port .....	9
JWR4: Control Rear USB port .....	9
ATXPWR1~2: Power Connectors .....	10
CPU_FAN1~2, SYS_FAN1~2: Fan Connectors .....	11
JTPM1: TPM Module Connector .....	11
F_USB2~3: USB 2.0 Connectors .....	12
F_USB1: USB 3.0 Connector .....	12
BIOS Setup .....	13
BIOS Setup .....	13
Enter BIOS Setup .....	14
Reset BIOS .....	14
FAQs .....	15
No Boot .....	15
Start-up - Shutdown .....	15
Repeated Reboots .....	15
No Video .....	16
Blue Screen, Crash .....	16

# Specifications

X99 U9			
<b>Processor</b>	Supports 5th/6th generation Intel Core i7 processors and XEON E5 V3/V4 series processors.		
<b>Southbridge</b>	Intel C612 Chipset		
<b>RAM</b>	Technology	4 Channel DDR4	
	Maximum Capacity	128GB (32GB*4)	
	Memory Slot	4 * DDR4	
<b>Rear I/O</b>	PS/2	2	
	Display Interface	0	
	USB	4 * USB 2.0; 4 * USB3.0	
	Ethernet	1 * Gigabit LAN	
	AUDIO	1 (Mic-in, Line-out、Line-in)	
<b>Internal connector</b>	CPU_FAN	2 * 4PIN	
	SYS_FAN	2 * 4PIN	
	ATXPWR	1 * 8PIN Power Socket; 1 * 24PIN Power Socket	
	USB2.0	2	
	USB3.0	1	
	M.2	3 * NVME M.2; 1 * WiFi M.2	
	SATA Interface	6 * SATA 3.0	
	F_AUDIO	1	
	JCOM	1	
	JCMOS Port	1	
	SPKR	1	
	JTPM	1	
	JWR1	1	
	JWR4	1	
	PCIe	1 * PCIe x16; 1 * PCIe x4	
	SPK	1	
<b>Environment</b>	Temperature Range	Working Environment	Storage Environment
		Temperature: 0~50°C Humidity: 5%~95%	Temperature: -20~70°C Humidity: 5%~95%
<b>Physical Size</b>	Size	245mm*197mm	

# Overview of Components

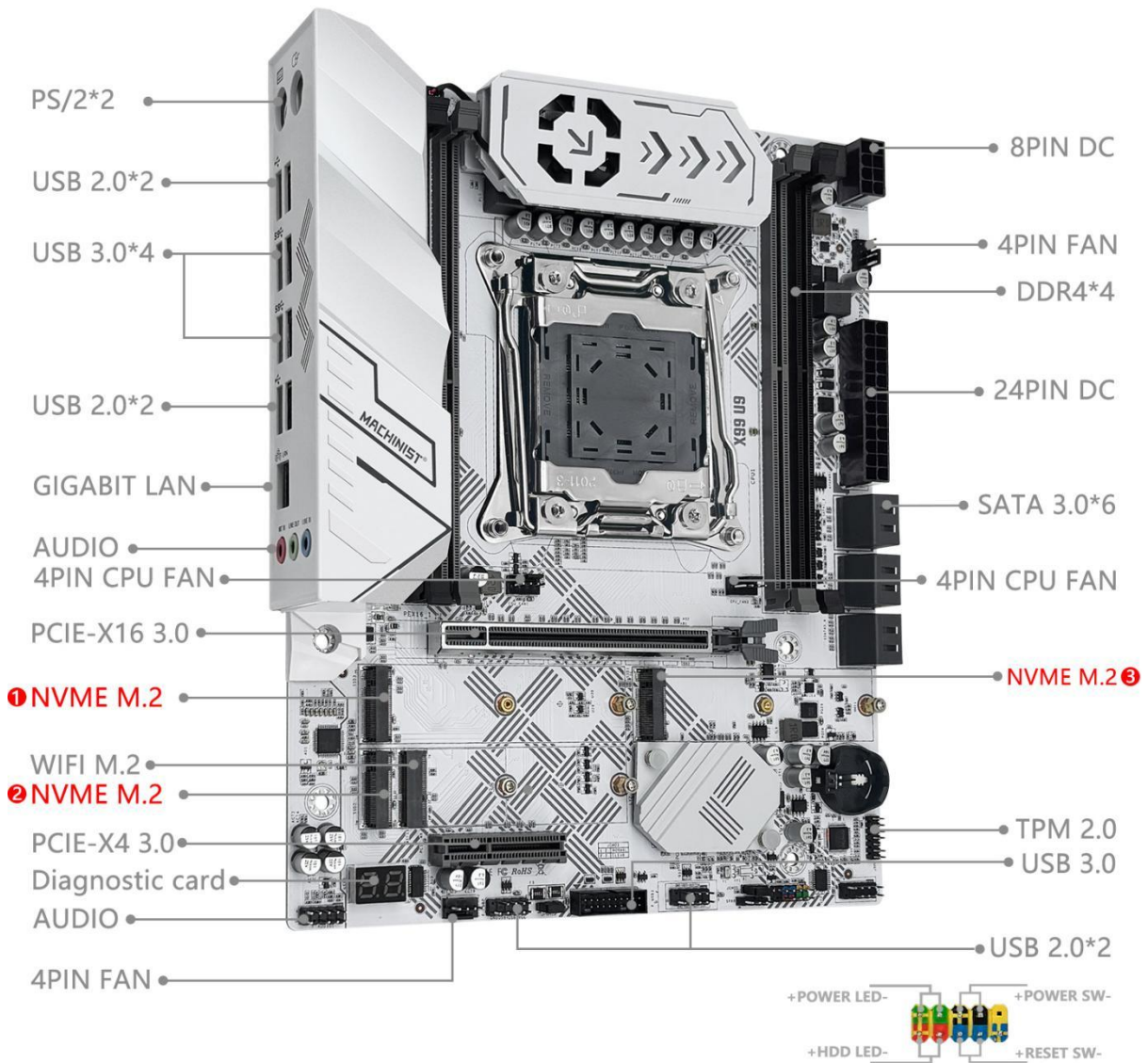

**Package List:**

- X99 U9 Motherboard \* 1
- SATA Cable \* 1
- I/O Blocking \* 1
- CPU fan bracket \* 1

## Install CPU & Fan

Please install the CPU into the CPU socket (LGA 2011-3) as shown below.

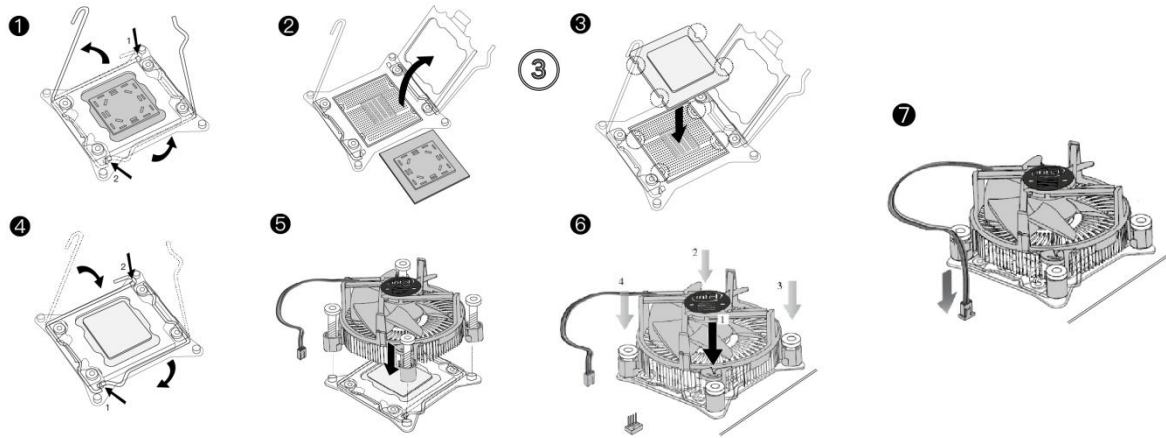

### **Important**

- Make sure that the motherboard supports the CPU.
- Always unplug the power cord from the power outlet before installing or removing the CPU to prevent hardware damage.
- Please retain the CPU protective cap after installing the processor.
- Do not turn on the computer if the CPU cooler is not installed, otherwise overheating and damage to the CPU may occur.
- Confirm that the CPU heatsink has formed a tight seal with the CPU before booting your system.
- Apply an even layer of thermal paste (or thermal tape) between the CPU and the heatsink to enhance heat dissipation.
- Whenever the CPU is not installed, always protect the CPU socket pins by covering the socket with a plastic cap.
- Locate the pin one of the CPU socket and the CPU. Once the CPU is positioned into its socket, place one finger down on the middle of the CPU, lowering the locking lever and latching it into the fully locked position.
- Do not force the CPU into the CPU socket before the CPU socket locking lever is lifted up, or damage to the CPU and CPU socket may occur.
- Connect the CPU heatsink's 4pin fan power connector to the 4pin CPU fan header on the motherboard.
- Please be sure to plug in the 8-PIN power supply to power the CPU.

## Install Memory

The motherboard provides 4 DDR4 DIMM slots with a maximum capacity of 128GB.

1. Wrench the latches on both sides of the memory slot outwards.
2. Insert the memory into the slot by aligning it with the notch in the slot.
3. Flip the latches on both sides of the slot to lock the memory.

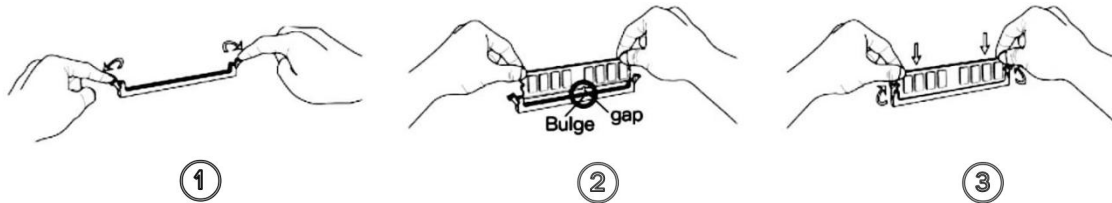

### **Important**

- Make sure that the motherboard supports the memory. It is recommended that memory of the same capacity, brand, speed, and chips be used.
- Always turn off the computer and unplug the power cord from the power outlet before installing the memory to prevent hardware damage.
- Memory modules have a foolproof design. A memory module can be installed in only one direction. If you are unable to insert the memory, switch the direction.
- The stability and compatibility of the installed memory module depend on the installed CPU and devices when overclocking.
- This motherboard provides 4 memory sockets and supports 4 Channel Technology. 4-Channel mode cannot be enabled if only one memory module is installed. (Note: Server memory and desktop memory cannot be used together.)
- The E5 V3 supports a maximum frequency of 2133MHz, and the E5 V4 supports a maximum frequency of 2400MHz.
- I7 series processors are not compatible with Desktop RAM.

## Install Expansion Card

The motherboard provides 1 PCI Express 3.0 X16 expansion slot and 1 PCI Express 3.0 x4 expansion slots.

Place the expansion card in an available PCI Express slot and press the expansion card until it is fully inserted into the slot.

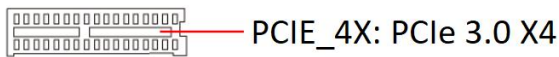
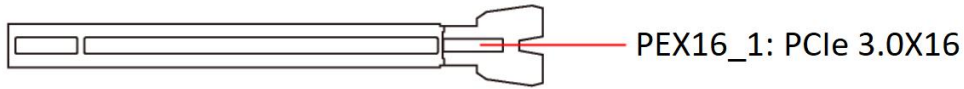

### **Important**

- When adding or removing expansion cards, always turn off the power supply and unplug the power supply power cable from the power outlet to prevent hardware damage.
- If the expansion card is not installed correctly, it may cause a short circuit throughout the metal pins, which could burn out the expansion card or the motherboard.

## Back Panel Connectors

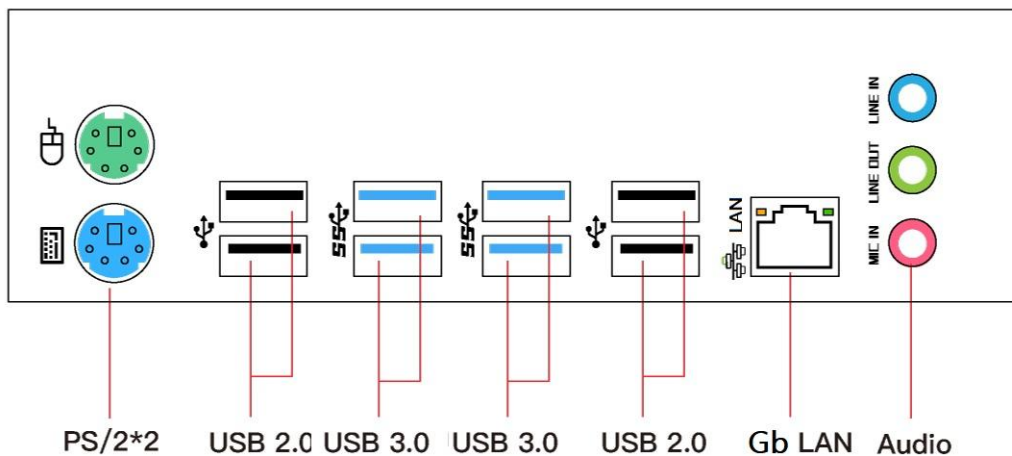

### USB 2.0 Port

The USB port supports the USB 2.0 specification. Use this port for USB devices.

## USB 3.0 Port

The USB 3.0 supports the USB 3.0 specification and is compatible to the USB 2.0 specification. Use this port for USB devices.

## RJ45 LAN Port

The Gigabit Ethernet LAN port provides Internet connection at up to 1000Mbps/s data rate. The following describes the states of the LAN port LEDs.

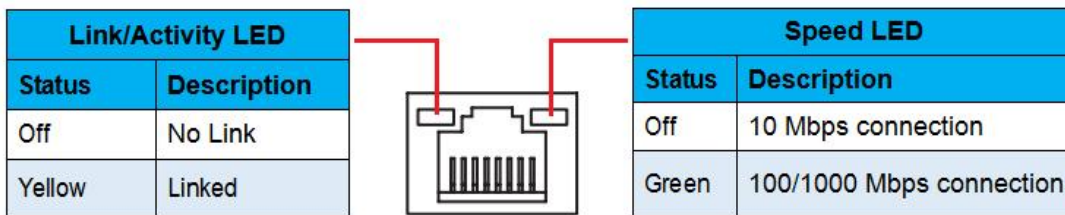

## Audio Port

### Line-in Port

The line in jack. Use this audio jack for line in devices such as an optical drive, walkman, etc.

### Line-out Port

The line out jack.

### Mic-in Port

The Mic in jack.

## PS/2 Port

The PS/2 port of the mouse is green, and the PS/2 port of the keyboard is blue.

## Internal Connectors

### F\_PANEL1 Connector

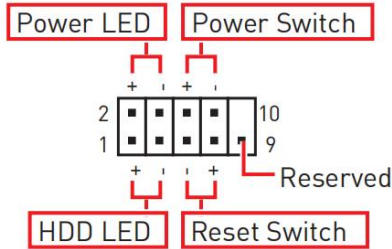

### SPKR Connector

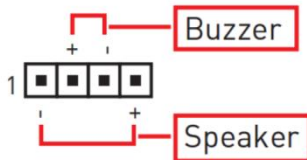

### F\_AUDIO1 Connector

This connector allows you to connect audio jacks on the front panel.

	1	MIC L	2	Ground
	3	MIC R	4	NC
	5	Head Phone R	6	MIC Detection
	7	SENSE_SEND	8	No Pin
	9	Head Phone L	10	Head Phone Detection



### Important

- An incorrect connection between the module connector and the motherboard header will make the device unable to work or even damage it.

### SATA1~6: SATA 3.0 Connectors

These SATA 3.0 connectors are SATA 6Gb/s interface ports. Each SATA connector supports a single SATA device.

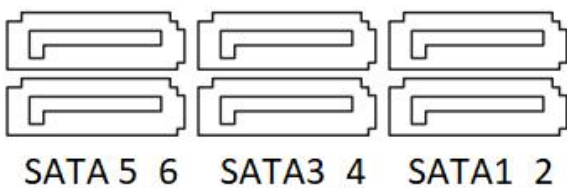

### SSD1~3: NVME M.2 Slot

The motherboard provides 3 NVME M.2 (PCIe 3.0 x4) slots.

Insert your M.2 SSD into the M.2 slot at a 30-degree angle. Secure the M.2 SSD in place with the screw.

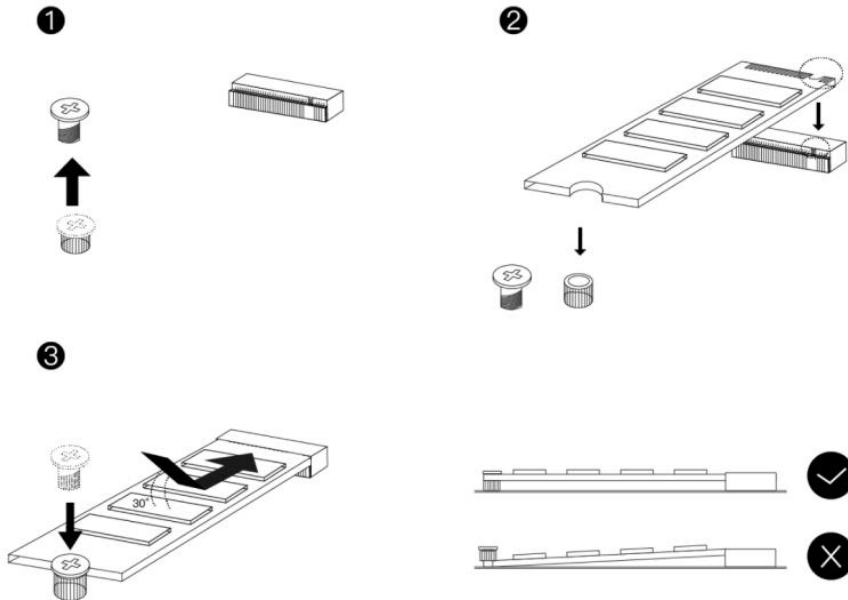

### WIFI1: WIFI M.2 Slot

The M.2 WiFi interface, which is compatible with WiFi AC standard expansion cards, can be used after the M.2 WiFi module is installed and the corresponding driver is loaded.

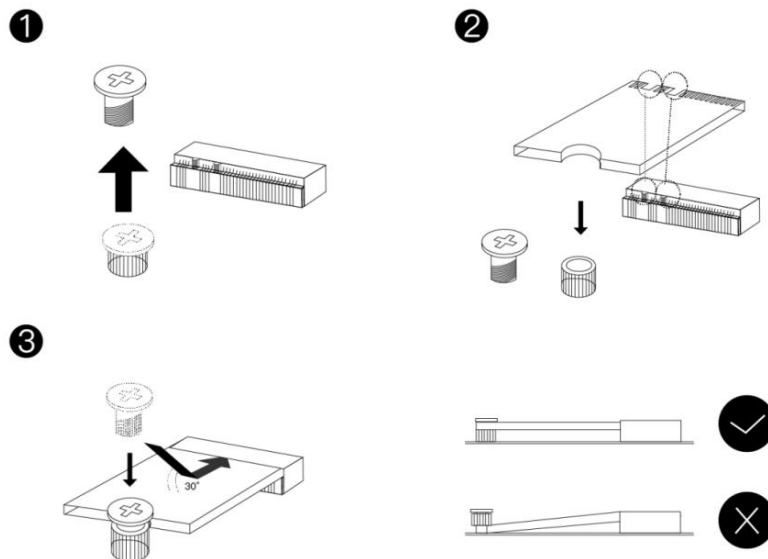

### JCMOS: Clear CMOS



**1.JCMOS (Initial state)**  
The initial state covers "1" and "2". If you want to discharge, please go to the next step.



**2.JCMOS (Discharge)**  
Pull out the cap to cover "2" and "3", and wait for about 3 minutes for the discharge to complete.



**3.JCMOS (Restitute)**  
After the discharge is completed, restore the initial state of the first step



### **Important**

- Always turn off the computer and unplug the power cord from the power outlet before discharging.

### JCOM1: Serial Port Connector

The COM connector can provide one serial port via an optional COM port cable.

	1	DCD	2	SIN
	3	SOUT	4	DTR
	5	Ground	6	DSR
	7	RST	8	CTS
	9	RI	10	NC

### JWR2: Control Front USB port

Controls whether the front USB port is powered on after the device is powered off; it is enabled by default.



Open: Normal



Close

### JWR4: Control Rear USB port

Controls whether the rear USB port is powered on after the device is powered off; it is enabled by default.



Open: Normal

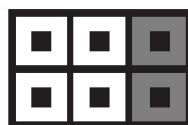

Close

## ATXPWR1~2: Power Connectors

With the use of the power connector, the power supply can provide enough stable power to all the components on the motherboard. Before connecting the power connector, make sure the power supply is turned off and all devices are properly installed.

 **Important**

- It is recommended that a power supply that can withstand high power consumption be used (at least 500W). If a power supply is used that does not provide the required power, the result can lead to an unstable or unbootable system.

24PIN for motherboard power supply.

8PIN for CPU power supply.

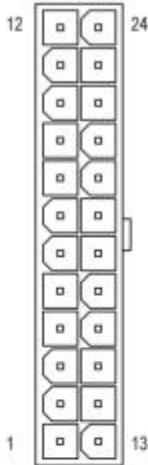
 <p><b>ATXPWR1</b></p>	1	+3.3V	13	+3.3V
	2	+3.3V	14	-12V
	3	Ground	15	Ground
	4	+5V	16	PS-ON
	5	Ground	17	Ground
	6	+5V	18	Ground
	7	Ground	19	Ground
	8	Power OK	20	NC
	9	5VSB	21	+5V
	10	+12V	22	+5V
	11	+12V	23	+5V
	12	+3.3V	24	Ground

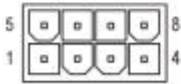
 <p><b>ATXPWR2</b></p>	1	Ground	5	+12V
	2	Ground	6	+12V
	3	Ground	7	+12V
	4	Ground	8	+12V

## CPU\_FAN1~2, SYS\_FAN1~2: Fan Connectors

CPU\_FAN is a interface for CPU cooler. The 4pin fan has PWM intelligent speed regulation function, which can intelligently control the fan speed based on load and temperature changes. (Only CPU\_FAN1 can identify the rotation speed.)

SYS\_FAN is the system cooling fan interface, which is generally connected to the case fan. The 4pin fan has PWM intelligent speed regulation function

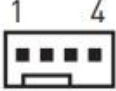
 CPU_FAN/SYS_FAN	1	Ground
	2	+12V
	3	Sense
	4	Speed Control

## JTPM1: TPM Module Connector

This connector is used for the TPM (Trusted Platform Module).

- Compatible only with ASUS TPM 2.0 modules; not compatible with MSI TPM 2.0 modules.
- For more detailed information and usage instructions, refer to the TPM Security Platform Manual.

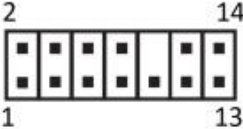
	1	LPC Clock	2	3V Standby Power
	3	LPC Reset	4	3.3V Power
	5	LPC address & data pin0	6	Serial IRQ
	7	LPC address & data pin1	8	5V Power
	9	LPC address & data pin2	10	No Pin
	11	LPC address & data pin3	12	Ground
	13	LPC Frame	14	Ground

### F\_USB2~3: USB 2.0 Connectors

The headers conform to USB 2.0 specification. This connector allows you to connect USB 2.0 ports on the front panel.

1	VCC	2	VCC
3	USB0-	4	USB1-
5	USB0+	6	USB1+
7	Ground	8	Ground
9	No Pin	10	NC

### F\_USB1: USB 3.0 Connector

The header conforms to USB 3.0 and USB 2.0 specification. This connector allows you to connect USB 3.0 ports on the front panel.

1	VBUS	11	D2+
2	SSRX1-	12	D2-
3	SSRX1+	13	Ground
4	Ground	14	SSTX2+
5	SSTX1-	15	SSTX2-
6	SSTX1+	16	Ground
7	Ground	17	SST2+
8	D-	18	SST2-
9	D+	19	VBUS
10	NC	20	No Pin

## BIOS Setup

BIOS (Basic Input and Output System) records hardware parameters of the system in the CMOS on the motherboard. BIOS identifies, configures, tests and connects computer hardware to the OS immediately after a computer is turned on.

Its major functions include conducting the Power-On Self-Test (POST) during system startup, saving system parameters and loading the operating system, etc. BIOS includes a BIOS Setup program that allows the user to modify basic system configuration settings or to activate certain system features.

When the power is turned off, the battery on the motherboard supplies the necessary power to the CMOS to keep the configuration values in the CMOS.



### **Important**

- Because BIOS flashing is potentially risky if you do not encounter problems using the current version of BIOS, it is recommended that you not flash the BIOS. To flash the BIOS, do it with caution. Inadequate BIOS flashing may result in system malfunction.

## BIOS Setup

The default settings offer the optimal performance for system stability in normal conditions. It is recommended that you not alter the default settings (unless you need to) to prevent system instability or other unexpected results. Inadequately altering the settings may result in the system's failure to boot.



### **Important**

- BIOS items are regularly updated for better system performance. The items may be slightly different from the latest BIOS; therefore, the description is for reference only.

### BIOS Settings:

Secure Boot: Support

TPM 2.0: Support

Wake-on-LAN: Support

Modify Memory Timings: Support

Above 4G Decoding: Support

Re-Size BAR Decoding: Support

Modify Fan Speed: Support

Boot Without Graphics Card: Support

Power On After Power Failure: Support

RAID: RAID0, RAID1, RAID5

Sleep Mode: Support

## Enter BIOS Setup

When the computer is turned on, BIOS enters the self-test process.

The following message will display after the self-test is completed: Press the " DEL " key to enter the BIOS Setup Menu. Or use the " Quick Boot Key" to press the F11.

If this message disappears before you press <DEL> key, you can turn it off and then turn on your computer or press <Reset> on the case to restart your computer. You can also press <Ctrl>+<Alt>+<Delete> at the same time to restart your computer.

It is recommended to repeatedly press the "Del" key immediately after starting the computer to ensure that the computer can enter BIOS mode.



### **Important**

- Functions may vary depending on the product you have.

## Reset BIOS

When you need to restore the default BIOS settings to resolve certain issues, the following step for quick reset the BIOS:

- Short the Clear CMOS jumper on the motherboard.



### **Important**

- Be sure the computer is off before clearing CMOS data. Please refer to the Clear CMOS jumper section for resetting BIOS.

## FAQs

### No Boot

Press the computer boot button, the computer does not respond (fan does not rotate, indicator light does not light).

1. Clear CMOS.
2. Check whether the CPU model is compatible with the motherboard.
3. Check whether the motherboard power supply, CPU power supply is plugged in, chassis power switch is turned on.
4. Check whether the chassis power-on cable is plugged in properly.
5. Check whether the power supply is good.
6. Unplug the graphics card, hard disk, USB and other devices, and then try to boot (it is best to use metal objects to directly short the switch pins, so that you can rule out the chassis switch problem).
7. Replace the CPU.

### Start-up - Shutdown

Press the start button and the fan turns for a while, then it turns off.

1. Clear CMOS.
2. Check whether the CPU model is compatible with the motherboard.
3. Replace the CPU and troubleshoot if the CPU is damage.
4. Replace the RAM and check if the RAM is damage.
5. Unplug the graphics card, hard disk, USB device, and then reboot.

### Repeated Reboots

The computer will restart repeatedly.

1. Clear CMOS.
2. Check whether the CPU model is compatible with the motherboard.
3. Replace the CPU and troubleshoot if the CPU is damage.
4. Replace the RAM and check if the RAM is damage.
5. Unplug the graphics card, hard disk, USB and other devices, and then reboot.

## No Video

The fan is rotating, press the keyboard case-switching key (CapsLK), the keyboard indicator does not respond.

1. Clear CMOS.
2. Check the motherboard power supply, CPU power supply is plugged.
3. Check the location of the memory stick installation, determine whether the memory location is inserted correctly (some models of the motherboard memory slot can not be randomly inserted, if you are not sure, please contact us through the online communication tool).
4. Check whether the CPU and memory model is compatible with the motherboard.
5. Replace the CPU, check whether the CPU is damage.
6. Replace the memory, check whether the memory is damage.

The fan is rotating, press the keyboard case-switching key (CapsLK), the keyboard light responds.

1. Check if the monitor is on.
2. Check whether the monitor display cable is plugged in (DP,HDMI,DVI,VGA).
3. Replace the monitor cable, check whether the monitor cable is bad.
4. Replace the graphics card to check whether the monitor is damage.

## Blue Screen, Crash

1. Check whether the heat dissipation is done properly, whether the CPU cooler fan is rotating, whether the base of the cooler and the CPU are tightly fitted, and whether the thermal paste is applied.
2. Replace the CPU.
3. Replace the memory.
4. Replace the hard disk.
5. Replace the system.
6. Replace the power supply.